

Z4 Series DC Motors



- Frame sizes: 100-450
- Insulation class: F
- Duty cycle: S1
- Rotation speed: 3000,1500,1000,750,600,500,400,300,200r/min
- Rated output: 1.5-600kW
- Voltage:160V / 440V
- Excitation mode: Separate excitation

Application: Widely applied in the industry of metallurgy, papermaking, printing, textile, printing and dyeing, cement and machine tools.

Features: Great speed control system by which speed can be reduced by lowering voltage with constant torque or raised by lowering exciting current with constant output; wide range of speed regulation; small size, lightweight; high output power, strong overload capacity.

Circumstance: Altitude not exceeds 1000m, highest ambient temperature shall be no higher than +40°C; can't work in the circumstance where acidic/alkaline gas, or some other gas that may damage the insulation exist; the motor powered by rectifier supply; standard exciting voltage is 180V, reinforced excitation is allowed but

Designation of Types

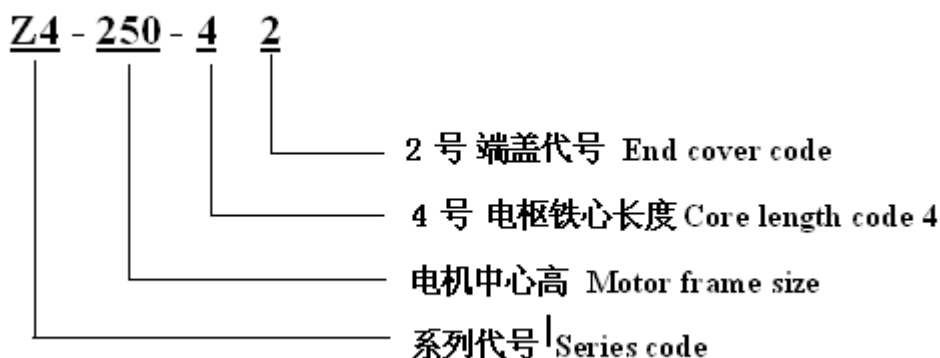

Mounting and Structure

1. Enclosure and mounting type

- Protection class is IP21S, IP23 or IP44.
- Mounting type see below table (frame with feet).

Mounting	Frame size
<p>IMB3</p>	Z4-100~Z4-450

GUANGZHOU HAOQING MOTOR CO.,LTD

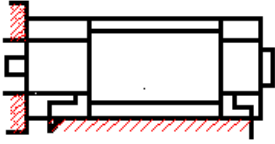
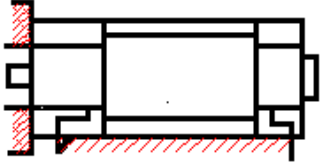
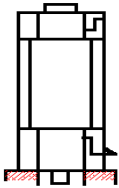
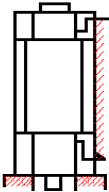
 <p style="text-align: center;">IMB35</p>	<p style="text-align: center;">Z4-100~Z4-315</p>
 <p style="text-align: center;">IMB5</p>	<p style="text-align: center;">Z4-100~Z4-315 (feet are not for installation purpose)</p>
 <p style="text-align: center;">IMV1</p>	<p style="text-align: center;">Z4-100~Z4-315 (feet are not for installation purpose)</p>
 <p style="text-align: center;">IMV15</p>	<p style="text-align: center;">Z4-100~Z4-315</p>

2. Cooling method

This series motors are cooled by forced air with separated built-on blower which is connected to independent power supply, and also fitted with air filter. The cooling method of the motor is IC06, motor of IC17, IC37 can also be customized.

- a. Z4-100~Z4-160, blower locates at NDE
- b. Z4-180~Z4-450, blower locates at DE
- c. Parameter of the cooling air and blower motor power see table (three phase, 2 poles, 380V).

Noted: Consult the producer when clients are interested in the following type motor:

- a. Frame size Z4-100~Z4-225 totally enclosed self-cooled motor (IC410).
- b. Frame size Z4-180~Z4-450 separately-cooled motor, blower at NDE (IC06).
- c. Frame size Z4-100~Z4-200 self-cooled motor, fan on the shaft (IC01).
- d. Frame size Z4-160~Z4-355 totally enclosed motor with air-air cooler (IC666).
- e. Frame size Z4-160~Z4-450 totally enclosed motor with air-water cooler (IC86W).

3. Terminal box is at the right side of the frame from the view of DE (The motor whose terminal box is at the left side or on the top can be also customized).

4. Motor whose speed generator or rotary encoder is at NDE can also be customized.

GUANGZHOU HAOQING MOTOR CO.,LTD

5. Motor is connected to flexible coupling.

Sheet 1

Frame	Blowing rate	Pressure	Output Power
	m ³ /h	pa	kW
Z4-100	160	200	0.04
Z4-112	220	300	0.06
Z4-132	360	450	0.18
Z4-160	790	600	0.37
Z4-180	1200	940	1.1
Z4-200	1600	800	1.1
Z4-225	2880	1400	3.0
Z4-250	3000	1400	3.0
Z4-280	4000	1600	4.0
Z4-315	4680	1600	5.5
Z4-355	5200	1600	5.5
Z4-400	7200	1800	5.5
Z4-450	9000	1800	7.5

GUANGZHOU HAOQING MOTOR CO.,LTD

Performance Data

Type	Rated Output P _N	Rated Speed		Speed with Field Weakened n _F	Arm. Curr. I _N	Field Power P _F	Arm. Circuit Resistance R	Arm. Circuit Resistance L _A	Field Inductance L _F	Smoothing Induct. L _R	Eff.	Moment of inertia GD ²	Wt.	
		160												
	kW	r/min		r/min	A	W	Ω(20°C)	mH	H	mH	%	kg·m ²	kg	
Z4-100-1	2.2	1490		3000	17.9	315	1.19	11.2	22	15	67.8	0.044	72	
	1.5	955		2000	13.3		2.17	21.4	13	15	58.5			
	4		2630	4000	12		2.82	26	18		78.9			
	4			2960	4000		10.7	2.82	26	18				80.1
	2		1310	3000	6.6		9.12	86	18		68.4			
	2.2			1480	3000		6.5	9.12	86	18				70.6
	1.4		860	2000	5.1		16.76	163	18		60.3			
	1.5			990	2000		4.77	16.76	163	18				63.2
Z4-112/2-1	3	1540		3000	24	320	0.785	7.1	14	20	69.1	0.072	100	
	2.2	975		2000	19.6		1.498	14.1	13	20	62.1			
	5.5		2630	4000	16.4		1.933	17.9	17		79.9			
	5.5			2940	4000		14.7	1.933	17.9	17				81.1
	2.8		1340	3000	9.1		6	59	17		71.2			
	3			1500	3000		8.6	6	59	17				72.8
	1.9		855	2000	6.9		11.67	110	13		61.1			
	2.2			965	2000		7.1	11.67	110	13				63.5
Z4-112/2-2	4	1450		3000	31.3	350	0.567	6.2	14	12	72.6	0.088	107	
	3	1070		2000	24.8		0.934	10.3	14	10	66.8			
	7		2660	4000	20.4		1.305	14	19		82.4			
	7.5			2980	4000		19.7	1.305	14	19				83.5
	3.7		1320	3000	11.7		4.24	48.5	19		74.1			
	4			1500	3000		11.2	4.24	48.5	19				76
	2.6		895	2000	9		7.62	83	14		65.1			
	3			1010	2000		9.1	7.62	83	14				67.3
Z4-112/4-1	5.5	1520		3000	42.5	500	0.38	3.85	6.8	6.5	73	0.128	106	
	4	990		2000	33.7		0.741	7.7	6.7	4.5	64.9			
	10		2680	3500	29		0.89	9	6.8		82.7			
	11			2950	3500		28.8	0.89	9	6.8				83.3
	5		1340	1800	15.7		3.01	30.5	6.8		74.3			
	5.5			1480	1800		15.4	3.01	30.5	6.8				75.7
	3.7		855	1100	13		5.78	60	6.7		65.2			
	4			980	1100		12.2	5.78	60	6.7				68.7
Z4-112/4-2	5.5	1090		2000	43.5	570	0.441	5.1	7.8	6	69.5	0.156	114	
	13		2740	3600	37		0.574	6.4	5.8		84.4			
	15			3035	3600		38.6	0.574	6.4	5.8				85.4
	6.7		1330	1800	20.6		2.12	24.1	7.8		76.8			
	7.5			1480	1800		20.6	2.12	24.1	7.8				78.4
	5		955	1200	16.1		3.46	40.5	5.8		71.1			
	5.5			1025	1200		15.7	3.46	40.5	5.8				71.9

GUANGZHOU HAOQING MOTOR CO.,LTD

Performance Data

Type	Rated Output POW	Rated Speed		Speed with Weakened Field	Arm. Current	Field POW	Arm. Circuit Resistance	Arm. Circuit Resistance	Field Inductance L _F	Eff.	Moment of Inertia GD ²	Wt.
		400V	440V									
	kW	r/min		r/min	A	W	Ω(20°C)	mH	H	%	kg·m ²	kg
Z4-132-1	18.5	2610		4000	52.2	650	0.368	5.3	6.5	85	0.32	140
	18.5		2850	4000	47.1		0.368	5.3	6.5	85.9		
	10	1330		2100	30.1		1.309	18.9	8.9	79.4		
	11		1480	2200	29.6		1.309	18.9	8.9	80.9		
	7	865		1600	22.7		2.56	37.5	6.3	71.9		
	7.5		975	1600	21.4		2.56	37.5	6.3	74.5		
Z4-132-2	20	2800		3600	55.4	730	0.226	3.65	10	87.8	0.4	160
	22		3090	3600	55.3		0.226	3.65	10	88.3		
	15	1360		2500	44.5		0.811	13.5	7.7	81.2		
	15		1510	2500	39.5		0.811	13.5	7.7	83.4		
	10	905		1400	31.1		1.565	26	6	75.6		
	11		995	1400	30.5		1.565	26	6	77.7		
Z4-132-3	27	2720		3600	74.5	800	0.1905	3.4	21	88.2	0.48	180
	30		3000	3600	75		0.1905	3.4	21	88.6		
	18.5	1390		2100	53.2		0.531	9.8	6.6	83.6		
	18.5		1540	2200	47.6		0.531	9.8	6.6	84.7		
	13.5	945		1600	40.5		0.976	19.4	6.5	79.4		
	15		1050	1600	40.5		0.976	19.4	6.5	80.5		
Z4-160-11	33	2710		3500	93.4	820	0.1835	3.15	10	87.4	0.64	220
	37		3000	3500	93.4		0.1835	3.15	10	88.5		
	19.5	1350		3000	58.8		0.593	10.4	7.7	80.4		
	22		1500	3000	58.8		0.593	10.4	7.7	82.6		
Z4-160-22	40.5	2710		3500	113	920	0.1426	2.7	10	88.2	0.76	242
	45		3000	3500	113		0.1426	2.7	10	89.1		
Z4-160-21	16.5	900		2000	50.5	920	0.862	17.7	6	77.9	0.76	242
	18.5		1000	2000	50.5		0.862	17.7	6	79.4		
Z4-160-32	49.5	2710		3500	137	1050	0.097	2.07	11	89.1	0.88	268
	55		3010	3500	137		0.097	2.07	11	90.2		
Z4-160-31	27	1350		3000	77.8	1050	0.376	8.3	10	84.7	0.88	268
	30		1500	3000	77.8		0.376	8.3	10	85.7		
	19.5	900		2000	59.1		0.675	15.2	6.3	79.1		
	22		1000	2000	59.1		0.675	15.2	6.3	81.7		
Z4-180-11	33	1350		3000	95.4	1200	0.29	5.8	7.1	84.7	1.52	326
	37		1500	3000	95.4		0.29	5.8	7.1	86.5		
	16.5	670		1900	51.4		0.947	17.6	5.6	75.5		
	18.5		750	1900	51.4		0.947	17.6	5.6	78.1		
	13	540		1400	42.4		1.264	25	5.6	73		
	15		600	1400	42.4		1.264	25	5.6	74.1		

GUANGZHOU HAOQING MOTOR CO.,LTD

Performance Data

Type	Rated Output P _N	Rated Speed		Speed with Field Weakened n _F	Arm. Curr. I _N	Field Power P _F	Arm. Circuit Resistance R	Arm. Circuit Resistance L _A	Field Inductance L _F	Eff.	Moment of Inertia GD ²	Wt.
		400V	440V									
	kW	r/min		r/min	A	W	Ω(20°C)	mH	H	%	kg·m ²	kg
Z4-180-22	67	2710		3400	185	1400	0.0555	1.16	6.9	89.5	1.72	350
	75		3000	3400	185		0.0555	1.16	6.9	90.7		
Z4-180-21	40.5	1350		2800	115	1400	0.2125	4.65	6.6	85.8	1.72	350
	45		1500	2800	115		0.2125	4.65	6.6	87		
	27	900		2000	79		0.419	9.3	7.3	82.2		
	30		1000	2000	79		0.419	9.3	7.3	83.7		
	19.5	670		1400	61		0.756	15.7	7.1	77.3		
	22		750	1400	61		0.756	15.7	7.1	79.7		
	16.5	540		1600	52		1.003	21.9	5	73.8		
	18.5		600	1600	52		1.003	21.9	5	76.8		
Z4-180-31	33	900		2000	97	1500	0.332	7.7	6.6	82.8	1.92	380
	37		1000	2000	97		0.332	7.7	6.6	83.6		
	19.5	540		1250	62		0.801	19	6.6	74.8		
	22		600	1250	62		0.801	19	6.6	76.6		
Z4-180-42	81	2710		3200	221	1700	0.051	1.16	12	91	2.2	410
	90		3000	3200	221		0.051	1.16	12	91.3		
Z4-180-41	50	1350		3000	139	1700	0.1417	3.2	5.7	87.5	2.2	410
	55		1500	3000	139		0.1417	3.2	5.7	87.7		
	27	670		2000	80		0.459	10.4	6.3	80.4		
	30		750	2000	80		0.459	10.4	6.3	81.1		
Z4-200-12	99	2710		3000	271	1400	0.0373	0.83	7.62	90.2	3.68	485
	110		3000	3000	271		0.0373	0.83	7.62	91.6		
Z4-200-11	40.5	900		2000	118	1400	0.2653	8.4	7.01	83.4	3.68	485
	45		1000	2000	118		0.2653	8.4	7.01	85.5		
	33	670		1600	99		0.369	10.6	7.77	80.2		
	37		750	1600	99		0.369	10.6	7.77	82.9		
	19.5	450		1000	64		0.93	21.9	7.3	72.2		
	22		500	1000	64		0.93	21.9	7.3	77.4		
Z4-200-21	67	1350		3000	188	1500	0.0885	2.8	6.78	88.7	4.2	530
	75		1500	3000	188		0.0885	2.8	6.78	89.6		
	27	540		1000	82		0.535	14	9.64	78.8		
	30		600	1000	82		0.535	14	9.64	80.4		
Z4-200-32	119	2710		3200	322	1750	0.0266	0.79	10.9	91.7	4.8	580
	132		3000	3200	322		0.0266	0.79	10.9	92.4		
Z4-200-31	81	1350		2800	224	1750	0.0771	2.6	5.61	88.7	4.8	580
	90		1500	2800	224		0.0771	2.6	5.61	90		
	49.5	900		2000	141		0.1751	4.8	8.54	85.6		
	55		1000	2000	141		0.1751	4.8	8.54	87.1		
	40.5	670		1400	119		0.283	8.5	8.35	82.5		
	45		750	1400	119		0.283	8.5	8.35	84.1		
	33	540		1200	101		0.42	12.2	8.42	79.6		
	37		600	1200	101		0.42	12.2	8.42	82		
	27	450		750	84		0.598	17.1	8.4	77.5		
	30		500	750	84		0.598	17.1	8.4	79.5		

GUANGZHOU HAOQING MOTOR CO.,LTD

Performance Data

Type	Rated Output P _N	Rated Speed		Speed with Field Weakened n _F	Arm. Curr. I _N	Field Power P _F	Arm. Circuit Resistance R	Arm. Circuit Resistance L _A	Field Inductance L _F	Eff.	Moment of Inertia GD ²	Wt.
		400V	440V									
	kW	r/min		r/min	A	W	Ω(20°C)	mH	H	%	kg·m ²	kg
Z4-225-11	99	1360		3000	276	2300	0.0664	2.1	4.45	87.9	5	680
	110		1500	3000	276		0.0664	2.1	4.45	89.4		
	67	900		2000	193		0.1406	4.9	4.28	84.4		
	75		1000	2000	193		0.1406	4.9	4.28	86.5		
	49	680		1300	146		0.2433	8.7	5.77	81.2		
	55		750	1300	146		0.2433	8.7	5.77	84		
	40	540		1200	123		0.356	9.5	6.38	78.2		
	45		600	1200	123		0.356	9.5	6.38	80.8		
	33	450		1000	103		0.476	15.2	6.10	76.5		
	37		500	1000	103		0.476	15.2	6.10	78.8		
Z4-225-21	49	540		1000	148	2470	0.2648	9.5	4.14	79.3	5.6	740
	55		600	1000	148		0.2648	9.5	4.14	82.4		
	40	450		1000	125		0.397	13.7	5.41	76.6		
	45		500	1000	125		0.397	13.7	5.41	78.9		
Z4-225-31	119	1360		2400	327	2580	0.0454	1.5	5.33	89.3	6.2	800
	132		1500	2400	327		0.0454	1.5	5.33	90.5		
	81	900		2000	227		0.093	3.4	5.3	86.9		
	90		1000	2000	227		0.093	3.4	5.3	88		
	67	680		2250	197		0.167	5.1	5.44	82.5		
	75		750	2250	197		0.167	5.1	5.44	85.1		
Z4-250-12	144	1360		2100	399	2500	0.0444	1.3	4.29	88.8	8.8	890
	160		1500	2100	399		0.0444	1.3	4.29	89.9		
Z4-250-11	99	900		2000	281	2500	0.0911	2.4	4.55	86.2	8.8	890
	110		1000	2000	281		0.0911	2.4	4.55	88.1		
Z4-250-21	167	1360		2200	459	2750	0.0325	0.91	4.28	89.8	10	970
	185		1500	2200	459		0.0325	0.91	4.28	90.5		
	81	680		2250	234		0.1306	3.9	5.41	83.2		
	90		750	2250	234		0.1306	3.9	5.41	85.2		
Z4-250-31	180	1360		2400	493	2850	0.0281	0.87	5.32	90.4	11.2	1070
	200		1500	2400	493		0.0281	0.87	5.32	91.5		
	119	900		2000	334		0.0668	1.7	5.46	87.4		
	132		1000	2000	334		0.0668	1.7	5.46	89.1		
	67	540		2000	204		0.202	4.0	4.0	80.8		
	75		600	2000	204		0.202	4.0	4.0	84.6		
	49	450		1500	152		0.305	7.3	5.1	78.5		
	55		500	1500	152		0.305	7.3	5.1	82.4		

GUANGZHOU HAOQING MOTOR CO.,LTD

Performance Data

Type	Rated Output P _N	Rated Speed		Speed with Field Weakened n _F	Arm. Curr. I _N	Field Power P _F	Arm. Circuit Resistance R	Arm. Circuit Resistance L _A	Field Inductanc e L _F	Eff.	Moment of Inertia GD ²	Wt.
		400V	440V									
	kW	r/min		r/min	A	W	Ω(20°C)	mH	H	%	kg·m ²	kg
Z4-250-41	198	1360		2400	539	3000	0.0237	0.93	6.19	91	12.8	1180
	220		1500	2400	539		0.0237	0.93	6.19	91.7		
	99	680		1900	283		0.0102	2.6	5.3	85.8		
	110		750	1900	283		0.0102	2.6	5.3	87.4		
	81	540		1600	236		0.141	4.7	6.36	83.4		
	90		600	1600	236		0.141	4.7	6.36	85		
	67	450		1500	201		0.195	5.1	4.97	80		
	75		500	1500	201		0.195	5.1	4.97	83.4		
Z4-250-42	144	900		2000	401	3000	0.0485	1.9	4.53	88	12.8	1180
	160		1000	2000	401		0.0485	1.9	4.53	89.2		
Z4-280-11	226	1355		2000	614	3100	0.02134	0.69	4.58	90.9	16.4	1280
	250		1500	2000	614		0.02134	0.69	4.58	91.6		
Z4-280-22	253	1355		1800	684	3500	0.01796	0.77	5.3	91.5	18.4	1400
	280		1500	1800	684		0.01796	0.77	5.3	92.1		
Z4-280-21	180	900		2000	498	3500	0.0373	1.2	4.46	89.1	18.4	1400
	200		1000	2000	498		0.0373	1.2	4.46	90.1		
	119	675		1600	333		0.0662	2.3	4.37	87.1		
	132		750	1600	333		0.0662	2.3	4.37	88.6		
	99	540		1500	281		0.093	3.1	4.57	84.7		
	110		600	1500	281		0.093	3.1	4.57	86		
Z4-280-32	284	1360		1800	768	3600	0.01493	0.59	6.94	91.7	21.2	1550
	315		1500	1800	768		0.01493	0.59	6.94	92.6		
	144	675		1700	402		0.0532	2	5.47	87.8		
	160		750	1700	402		0.0532	2	5.47	89.1		
Z4-280-31	198	900		2000	545	3600	0.0314	1.1	5.54	89.7	21.2	1550
	220		1000	2000	545		0.0314	1.1	5.54	90.6		
	118	540		1000	339		0.0839	2.6	5.77	85.4		
	132		600	1000	339		0.0839	2.6	5.77	86.8		
	80	450		1400	234		0.1377	5.3	9.03	84.1		
	90		500	1400	234		0.1377	5.3	9.03	85.4		
Z4-280-42	225	900		1800	616	4000	0.02545	0.96	5.29	90.2	24	1700
	250		1000	1800	616		0.02545	0.96	5.29	91.1		
Z4-280-41	166	675		1900	464	4000	0.0457	1.7	5.19	88.1	24	1700
	185		750	1900	464		0.0457	1.7	5.19	89.4		
	98	450		1000	282		0.0993	3.7	6.86	85.1		
	110		500	1000	282		0.0993	3.7	6.86	86.9		

GUANGZHOU HAOQING MOTOR CO.,LTD

Performance Data

Type	Rated Output P_N	Rated Speed		Speed with Field Weakened n_F	Arm. Curr. I_N	Field Power P_F	Arm. Circuit Resistance R	Arm. Circuit Resistance L_A	Field Inductance L_F	Eff.	Moment of Inertia GD^2	Wt.
		400V	440V									
	kW	r/min		r/min	A	W	$\Omega(20^\circ\text{C})$	mH	H	%	$\text{kg}\cdot\text{m}^2$	kg
Z4-315-12	321	1360		1800	865	3850	0.015	0.39	8.64	92.2	21.2	1890
	355		1500	1800	865		0.015	0.39	8.64	92.8		
	253	900		1600	690		0.02355	0.46	5.06	90.4		
	280		1000	1600	690		0.02355	0.46	5.06	91.6		
	180	680		1900	500		0.04371	0.83	4.97	88.4		
	200		750	1900	500		0.04371	0.83	4.97	89.4		
Z4-315-11	144	540		1900	409	3850	0.06919	1.3	7.6	86.4	21.2	1890
	160		600	1900	409		0.06919	1.3	7.6	87.4		
	118	450		1600	344		0.1	2.3	9.43	84.4		
	132		500	1600	344		0.1	2.3	9.43	86.3		
	98	360		1200	294		0.1415	2.9	9.96	81.7		
	110		400	1200	294		0.1415	2.9	9.96	84.3		
Z4-315-22	284	900		1600	772	4350	0.02034	0.49	5.91	91	24	2080
	315		1000	1600	772		0.02034	0.49	5.91	91.5		
	225	680		1600	624		0.03392	0.74	18.8	88.7		
	250		750	1600	624		0.03392	0.74	18.8	89.6		
Z4-315-21	166	540		1600	468	4350	0.05382	1.2	25	87.2	24	2080
	185		600	1600	468		0.05382	1.2	25	88.5		
	143	450		1500	413		0.076	1.5	19	84.7		
	160		500	1500	413		0.076	1.5	19	86		
Z4-315-32	320	900		1600	867	4650	0.01658	0.39	23.1	91	27.2	2290
	355		1000	1600	867		0.01658	0.39	23.1	92		
	252	680		1600	698		0.03043	0.82	21.5	89.1		
	280		750	1600	698		0.03043	0.82	21.5	89.8		
	180	540		1500	501		0.04536	0.95	31.6	88.2		
	200		600	1500	501		0.04536	0.95	31.6	89.4		
Z4-315-31	118	360		1200	344	4650	0.1002	2.1	23.3	83.2	27.2	2290
	132		400	1200	344		0.1002	2.1	23.3	85.3		
Z4-315-42	361	900		1400	971	5200	0.01302	0.33	29	92.1	30.8	2520
	400		1000	1400	971		0.01302	0.33	29	92.7		
	284	680		1600	778		0.02364	0.67	20.8	90		
	315		750	1600	778		0.02364	0.67	20.8	90.7		
	225	540		1600	626		0.03554	0.87	21.9	88.3		
	250		600	1600	626		0.03554	0.87	21.9	89		
Z4-315-41	166	450		1500	468	5200	0.055	1.4	37.4	87.3	30.8	2520
	185		500	1500	468		0.055	1.4	37.4	88.3		
	143	360		1200	416		0.0803	1.8	22.2	84		
	160		400	1200	416		0.0803	1.8	22.2	85.3		

GUANGZHOU HAOQING MOTOR CO.,LTD

Performance Data

Type	Rated Output P_N	Rated Speed		Speed with Field Weakened n_F	Arm. Curr. I_N	Field Power P_F	Arm. Circuit Resistance R	Arm. Circuit Resistance L_A	Field Inductance L_F	Eff.	Moment of Inertia GD^2	Wt.
		400V	440V									
	kW	r/min		r/min	A	W	$\Omega(20^\circ\text{C})$	mH	H	%	$\text{kg}\cdot\text{m}^2$	kg
Z4-355-12	406	900		1500	1094	4700	0.01259	0.36	37.6	91.8	42	2890
	450		1000	1500	1094		0.01259	0.36	37.6	92.8		
	321	680		1500	877		0.02087	0.59	28.1	90.4		
	355		750	1500	877		0.02087	0.59	28.1	91.2		
Z4-355-11	253	540		1500	697	4700	0.02952	0.91	22	89.2	42	2890
	280		600	1500	697		0.02952	0.91	22	90.2		
	180	450		1500	506		0.0502	1.5	8.91	87.6		
	200		500	1500	506		0.0502	1.5	8.91	88.9		
	166	360		1200	478		0.066	1.8	22.4	84.9		
	185		400	1200	478		0.066	1.8	22.4	85.9		
Z4-355-22	361	680		1600	978	5600	0.01583	0.44	15.6	90.8	46	3170
	400		750	1600	978		0.01583	0.44	15.6	91.7		
	284	540		1500	783		0.02676	0.81	34.7	89.5		
	315		600	1500	783		0.02676	0.81	34.7	90.5		
	225	450		1600	624		0.03462	1	20.5	88.4		
	250		500	1600	624		0.03462	1	20.5	89.5		
Z4-355-21	180	360		1200	511	5600	0.05642	1.6	35.5	86.3	46	3170
	200		400	1200	511		0.05642	1.6	35.5	87.5		
Z4-355-32	406	680		1100	1098	6000	0.01362	0.39	19	91.3	52	3490
	450		750	1100	1098		0.01362	0.39	19	92.1		
	320	540		1600	877		0.02153	0.7	24.3	89.9		
	355		600	1600	877		0.02153	0.7	24.3	91		
	284	450		1500	789		0.0293	0.91	18.5	88.3		
	315		500	1500	789		0.0293	0.91	18.5	89.5		
Z4-355-31	197	360		1200	559	6000	0.04957	1.3	34.6	86.6	52	3490
	220		400	1200	559		0.04957	1.3	34.6	88.4		
Z4-355-42	361	540		1300	985	6500	0.01836	0.64	29.6	90.5	60	3840
	400		600	1300	985		0.01836	0.64	29.6	91.2		
	320	450		1200	882		0.02361	0.76	17.7	88.9		
	355		500	1200	882		0.02361	0.76	17.7	89.2		
	225	360		1200	627		0.0358	1.2	17.7	87.5		
	250		400	1200	627		0.0358	1.2	17.7	88.8		

GUANGZHOU HAOQING MOTOR CO.,LTD

Performance Data

Type	Rated Output P _N	Rated Speed		Speed with Field Weakened n _F	Arm. Curr. I _N	Field Power P _F	Arm. Circuit Resistance R	Arm. Circuit Resistance L _A	Field Inductance L _F	Eff. %	Moment of Inertia GD ²	Wt. kg
		400V	440V									
	kW	r/min		r/min	A	W	Ω(20°C)	mH	H		kg·m ²	
Z4-400-22	435	680		1400	1175	5700	0.0139	0.33	7.85	90.8	74	4500
	480		750	1400	1175		0.0139	0.33	7.85	92		
Z4-400-21	235	360		1200	675	5700	0.0497	1	7.3	84.8	74	4500
	260		400	1200	675		0.0497	1	7.3	86.3		
	180	270		900	537		0.0804	1.6	7.44	81.8		
	200		300	900	537		0.0804	1.6	7.44	83.1		
Z4-400-32	500	680		1400	1340	6400	0.0112	0.3	9.57	91.2	84	4900
	550		750	1400	1340		0.0112	0.3	9.57	92.5		
	400	540		1300	1083		0.0162	0.35	4.51	89.9		
	440		600	1300	1083		0.0162	0.35	4.51	91.1		
	344	450		1300	952		0.0248	0.58	6	88.1		
	380		500	1300	952		0.0248	0.58	6	89.5		
Z4-400-31	270	360		1200	768	6400	0.03821	0.82	6.11	86	84	4900
	300		400	1200	768		0.03821	0.82	6.11	87.5		
	208	270		900	611		0.0659	1.5	5.89	82.8		
	230		300	900	611		0.0659	1.5	5.89	84		
Z4-400-42	435	540		1300	1175	7100	0.0134	0.32	5.54	90.8	94	5300
	480		600	1300	1175		0.0134	0.32	5.54	92		
	390	450		1400	1070		0.0201	0.47	6.86	88.6		
	430		600	1400	1070		0.0201	0.47	6.86	90		
Z4-400-41	316	360		1200	880	7100	0.0274	0.73	5.41	87.7	94	5300
	350		400	1200	880		0.0274	0.73	5.41	89		
	235	270		900	676		0.0508	1.2	5.38	84		
	260		300	900	676		0.0508	1.2	5.38	85.4		
Z4-450-22	472	540		1200	1286	6500	0.0133	0.29	10.2	90.8	138	5600
	520		600	1200	1286		0.0133	0.29	10.2	92.1		
	408	450		1400	1114		0.0159	0.41	7.99	90		
	450		500	1400	1114		0.0159	0.41	7.99	91.3		
	362	360		1200	1010		0.0232	0.61	5.79	88.1		
	400		400	1200	1010		0.0232	0.61	5.79	89.4		
Z4-450-21	253	270		900	720	6500	0.0415	1	5.82	85.8	138	5600
	280		300	900	720		0.0415	1	5.82	87.1		

GUANGZHOU HAOQING MOTOR CO.,LTD

Performance Data

Type	Rated Output P_N	Rated Speed		Speed with Field Weakened n_F	Arm. Curr. I_N	Field Power P_F	Arm. Circuit Resistance R	Arm. Circuit Resistance L_A	Field Inductance L_F	Eff. %	Moment of Inertia GD^2	Wt. kg
		400V	440V									
	kW	r/min		r/min	A	W	$\Omega(20^\circ\text{C})$	mH	H	%	$\text{kg}\cdot\text{m}^2$	kg
Z4-450-32	500	540		1200	1358	7100	0.0134	0.39	19.6	90.8	156	6000
	550		600	1200	1358		0.0134	0.39	19.6	92		
	453	450		1300	1228		0.0145	0.32	7.36	90		
	500		500	1300	1228		0.0145	0.32	7.36	91.4		
	408	360		1200	1130		0.0205	0.53	7.17	88.5		
	450		400	1200	1130		0.0205	0.53	7.17	89.7		
	309	270		900	875		0.0342	0.83	4.8	85.9		
	340		300	900	875		0.0342	0.83	4.8	87.1		
Z4-450-31	200	180		600	595	7100	0.0751	1.9	9.09	81.3	156	6000
	220		200	600	595		0.0751	1.9	9.09	82.6		
Z4-450-42	545	540		1100	1492	7800	0.0134	0.51	28.2	90.3	174	6700
	600		600	1100	1492		0.0134	0.51	28.2	91.5		
	500	450		1100	1367		0.0145	0.43	18.6	90		
	550		500	1100	1367		0.0145	0.43	18.6	91.4		
	453	360		1200	1254		0.0178	0.42	5.85	88.9		
	500		400	1200	1254		0.0178	0.42	5.85	90		
	345	270		900	927		0.0275	0.81	5.62	86.8		
	380		300	900	927		0.0275	0.81	5.62	88.1		
Z4-450-41	235	180		600	698	7800	0.0612	1.7	5.73	81.7	174	6700
	260		200	600	698		0.0612	1.7	5.73	83		

Dimensions

mm

1. Horizontal and Foot-mounted

外形及安装尺寸 Dimensions

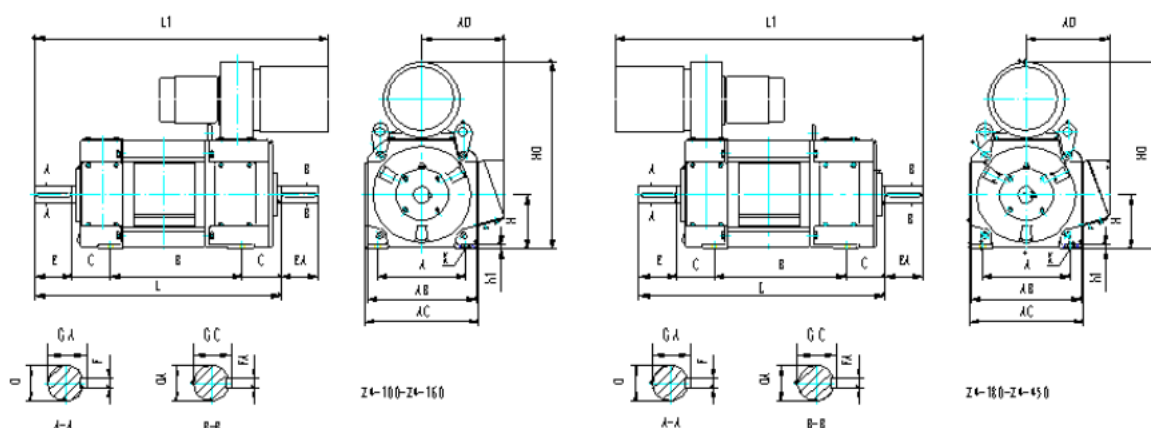

GUANGZHOU HAOQING MOTOR CO.,LTD

型号	安装尺寸 Mounting Dimensions													外形尺寸 Outline Dimensions						
	A	B	C	D	E	F	GA	DA	EA	FA	GC	H	K	AB	AC	AD	HD	L	L1	h1
Z4-100-1	160	318	63	24	50	8	27	24	50	8	27	100	12	197	234	179	398	500	580	10
Z4-100-2		358																540	620	
Z4-112/2-1	190	337	70	28	60	8	31	28	60	8	31	112	12	221	255	202	452	544	612	10
Z4-112/2-2		367																574	642	
Z4-112/2-3		407																614	682	10
Z4-112/2-4		477																684	752	
Z4-112/4-1	190	347	70	32	80	10	35	32	80	10	35	112	12	221	255	202	452	573	642	10
Z4-112/4-2		387																613	682	
Z4-112/4-3		437																663	732	10
Z4-112/4-4		497																723	792	
Z4-132-1	216	355	89	38	80	10	41	38	80	10	41	132	12	260	295	240	527	619	814	12
Z4-132-2		405																669	864	
Z4-132-3		465																729	924	12
Z4-132-4		545																809	1004	
Z4-160-11	254	411	108	48	110	14	51.5	48	110	14	51.5	160	15	316	346	283	625	744	953	14
Z4-160-12		476																809	986	
Z4-160-21		451																784	993	
Z4-160-22		516																849	1026	
Z4-160-31		501																834	1043	
Z4-160-32		566																899	1076	
Z4-160-41		561																894	1103	
Z4-160-42		626																959	1136	
Z4-160-51		631																964	1173	
Z4-160-52		696																1029	1206	
Z4-180-11		279																436	121	
Z4-180-12	501		859	1087																
Z4-180-21	476		834	1062																
Z4-180-22	541		899	1127																
Z4-180-31	526		884	1112																
Z4-180-32	591		949	1177																
Z4-180-41	586		944	1172																
Z4-180-42	651		1009	1237																
Z4-180-51	656		1014	1242																
Z4-180-52	721		1079	1307																

GUANGZHOU HAOQING MOTOR CO.,LTD

型号 Type	安装尺寸 Mounting Dimensions													外形尺寸 Outline Dimensions						
	A	B	C	D	E	F	GA	DA	EA	FA	GC	H	K	AB	AC	AD	HD	L	L1	h1
Z4-200-11	318	566	133	65	140	18	69	65	140	18	69	200	19	396	430	355	779	977	1158	18
Z4-200-12		614																1025	1206	
Z4-200-21		606																1017	1198	
Z4-200-22		654																1065	1246	
Z4-200-31		686																1097	1278	
Z4-200-32		734																1145	1326	
Z4-200-41		756																1167	1348	
Z4-200-42		804																1215	1396	
Z4-225-11		356																701	149	
Z4-225-12	761		1200	1665																
Z4-225-21	751		1190	1655																
Z4-225-22	811		1250	1715																
Z4-225-31	811		1250	1715																
Z4-225-32	871		1310	1775																
Z4-250-11	406	715	168	85	170	22	90	75	140	20	79.5	250	24	490	524	432	1031	1225	1657	25
Z4-250-12		775																1285	1717	
Z4-250-21		765																1275	1707	
Z4-250-22		825																1335	1767	
Z4-250-31		825																1335	1767	
Z4-250-32		885																1395	1827	
Z4-250-41		895																1405	1837	
Z4-250-42		955																1465	1897	
Z4-280-11	457	762	190	95	170	25	100	85	170	22	90	280	24	550	584	462	1130	1315	1748	25
Z4-280-12		852																1405	1838	
Z4-280-21		822																1375	1808	
Z4-280-22		912																1465	1898	
Z4-280-31		892																1445	1878	
Z4-280-32		982																1535	1968	
Z4-280-41		972																1525	1958	
Z4-280-42		1062																1615	2048	
Z4-280-51		1062																1615	2048	
Z4-280-52		1152																1705	2138	
Z4-315-091		508																817	216	
Z4-315-092	907		1552	1917																
Z4-315-11	887		1532	1897																
Z4-315-12	977		1622	1987																
Z4-315-21	967		1612	1977																
Z4-315-22	1057		1702	2067																
Z4-315-31	1057		1702	2067																
Z4-315-32	1147		1792	2157																
Z4-315-41	1157		1802	2167																
Z4-315-42	1247		1892	2257																

GUANGZHOU HAOQING MOTOR CO.,LTD

型号 Type	安装尺寸 Mounting Dimensions												外形尺寸 Outline Dimensions																								
	A	B	C	D	E	F	GA	DA	EA	FA	GC	H	K	AB	AC	AD	HD	L	L1	h1																	
Z4-355-081	610	818	254	110	210	28	116	110	210	28	116	355	28	700	734	701	1301	1539	1860	30																	
Z4-355-082		908																1629	1950																		
Z4-355-091		888																1609	1930																		
Z4-355-092		978																1699	2020																		
Z4-355-11		968																1689	2010																		
Z4-355-12		1058																1779	2100																		
Z4-355-21		1058																1779	2100																		
Z4-355-22		1148																1869	2190																		
Z4-355-31		1158																1879	2200																		
Z4-355-32		1248																1969	2290																		
Z4-355-41		1268																1989	2310																		
Z4-355-42		1358																2079	2400																		
Z4-400-11		686																959	280		120	210	32	127	120	210	32	127	400	35	790	830	750	1620	1732	1817	35
Z4-400-12																		1079																	1852	1937	
Z4-400-21	1039		1812	1897																																	
Z4-400-22	1159		1932	2017																																	
Z4-400-31	1129		1902	1987																																	
Z4-400-32	1249		2022	2107																																	
Z4-400-41	1229		2002	2087																																	
Z4-400-42	1349		2122	2207																																	
Z4-450-11	800	1061	315	140	250	36	148	140	250	36	148	450	35	890	924	800	1720	1944	2050	40																	
Z4-450-12		1181																2064	2070																		
Z4-450-21		1151																2034	2140																		
Z4-450-22		1271																2154	2260																		
Z4-450-31		1251																2134	2240																		
Z4-450-32		1371		2254	2360																																
Z4-450-41		1361		2294	2350																																
Z4-450-42		1481		2414	2470																																
Z4-450-51		1481		2414	2470																																
Z4-450-52		1601		2534	2590																																

GUANGZHOU HAOQING MOTOR CO.,LTD

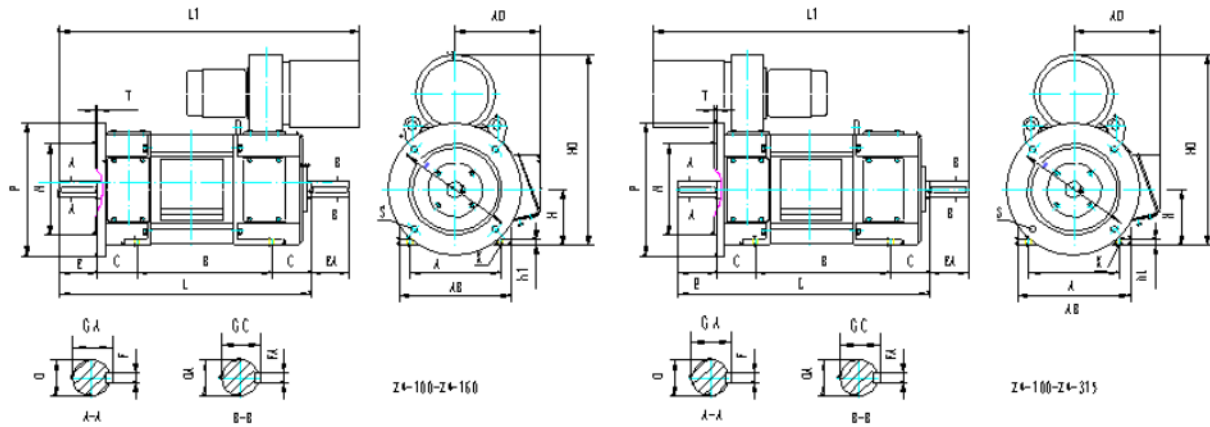

型号 Type	安装尺寸 Mounting Dimensions																外形尺寸 Outline Dimensions								
	A	B	C	D	E	F	GA	DA	EA	FA	GC	H	K	M	N	S	Holes	T	P	AB	AC	AD	HD	L	L1
Z4-100-1	160	318	63	24	50	8	27	24	50	8	27	100	12	215	180	15	4	4	250	197	234	179	398	500	580
Z4-100-2		358																						540	620
Z4-112/2-1	190	337	70	28	60	8	31	28	60	8	31	112	12	215	180	15	4	4	250	221	255	202	452	544	612
Z4-112/2-2		367																						574	642
Z4-112/2-3		407																						614	682
Z4-112/2-4		477																						684	752
Z4-112/4-1	190	347	70	32	80	10	35	32	80	10	35	112	12	215	180	15	4	4	250	221	255	202	452	573	642
Z4-112/4-2		387																						613	682
Z4-112/4-3		437																						663	732
Z4-112/4-4		497																						723	792
Z4-132-1	216	355	89	38	80	10	41	38	80	10	41	132	12	265	230	15	4	4	300	260	295	240	527	619	814
Z4-132-2		405																						669	864
Z4-132-3		465																						729	924
Z4-132-4		545																						809	1004
Z4-160-11	254	411	108	48	110	14	51.5	48	110	14	51.5	160	15	300	250	19	4	5	350	316	346	283	625	744	953
Z4-160-12		476																						809	986
Z4-160-21		451																						784	993
Z4-160-22		516																						849	1026
Z4-160-31		501																						834	1043
Z4-160-32		566																						899	1076
Z4-160-41		561																						894	1103
Z4-160-42		626																						959	1136
Z4-160-51		631																						964	1173
Z4-160-52		696																						1029	1206
Z4-180-11	279	436	121	55	110	16	59	55	110	16	59	180	15	350	300	19	4	5	400	365	390	305	731	794	1022
Z4-180-12		501																						859	1087
Z4-180-21		476																						834	1062
Z4-180-22		541																						899	1127
Z4-180-31		526																						884	1112
Z4-180-32		591																						949	1177
Z4-180-41		586																						944	1172
Z4-180-42		651																						1009	1237
Z4-180-51		656																						1014	1242
Z4-180-52		721																						1079	1307

GUANGZHOU HAOQING MOTOR CO.,LTD

型号 Type	安装尺寸 Mounting Dimensions																	外形尺寸 Outline Dimensions							
	A	B	C	D	E	F	GA	DA	EA	FA	GC	H	K	M	N	S	Holes	T	P	AB	AC	AD	HD	L	L1
Z4-200-11	318	566	133	65	140	18	69	65	140	18	69	200	19	400	350	19	8	5	450	396	430	355	779	977	1158
Z4-200-12		614																						1025	1206
Z4-200-21		606																						1017	1198
Z4-200-22		654																						1065	1246
Z4-200-31		686																						1097	1278
Z4-200-32		734																						1145	1326
Z4-200-41		756																						1167	1348
Z4-200-42		804																						1214	1396
Z4-225-11	356	701	149	75	140	20	79.5	75	140	20	79.5	225	19	500	450	19	8	5	550	440	474	398	981	1140	1605
Z4-225-12		761																						1200	1665
Z4-225-21		751																						1190	1655
Z4-225-22		811																						1250	1715
Z4-225-31		811																						1250	1715
Z4-225-32		871																						1310	1775
Z4-250-11	406	715	168	85	170	22	90	75	140	20	79.5	250	24	600	550	24	8	6	660	490	524	432	1031	1225	1657
Z4-250-12		775																						1285	1717
Z4-250-21		765																						1275	1707
Z4-250-22		825																						1335	1767
Z4-250-31		825																						1335	1767
Z4-250-32		885																						1395	1827
Z4-250-41		895																						1405	1837
Z4-250-42		955																						1465	1897
Z4-280-11	457	762	190	95	170	25	100	85	170	22	90	280	24	600	550	24	8	6	660	550	584	462	1130	1315	1748
Z4-280-12		852																						1405	1838
Z4-280-21		822																						1375	1808
Z4-280-22		912																						1465	1898
Z4-280-31		892																						1445	1878
Z4-280-32		982																						1535	1968
Z4-280-41		972																						1525	1958
Z4-280-42		1062																						1615	2048
Z4-280-51		1062																						1615	2048
Z4-280-52		1152																						1705	2138
Z4-315-11		508																						887	216
Z4-315-12	977		1622	1987																					
Z4-315-21	967		1612	1977																					
Z4-315-22	1057		1702	2067																					
Z4-315-31	1057		1702	2067																					
Z4-315-32	1147		1792	2157																					
Z4-315-41	1157		1802	2167																					
Z4-315-42	1247		1892	2257																					

Note: Dimensions here are indicative only. Actual product may differ. Data above may be changed without prior notice.
E-mail: sherry@gzhqmotor.com Website: http://www.gzhqmotor.com